



Jetties and Moorings

Approval of Jetties and Moorings

Generally, both planning and building licence approvals are required from the City of Mandurah for all structures within canal waterways. These approvals are required prior to the Department of Transport granting a licence for the structure. These approvals are required to:

- Ensure that waterway structures are designed and constructed in accordance with relevant legislative and construction requirements that City of Mandurah and the Department of Transport (Coastal Facilities) are responsible for, and to
- Ensure that proposed waterway structures will not create an adverse impact upon the visual amenity and environmental sensitivity and safety, (including user conflict) for users of the canals and property owners who abut a canal waterway.

Notwithstanding the above, **a planning application will not be required where it is proposed to construct only a jetty subject to the jetty being constructed within the prescribed jetty envelope and that it complies with the City's Local Planning Policy No 11 – Canal Waterways Structures.** This applies to proposed jetties in Port Mandurah canal lots, (except Stage 1, being the area bounded by Mary Street and Leighton Road east and west); Mariners Cove canal Lots; Port Bouvard canal lots.

Assessment Process

An application for a jetty or mooring piles shall be made on the attached planning and building licence application forms which should be lodged together with the following:

Application fees of \$132 for a planning application and a minimum of \$125 for a Building application apply.

For a planning application, three (3) sets of scaled plans of the proposed structure, including a site plan.

For a building application, two (2) sets of scaled plans of the proposed structure, including a site plan as well as two (2) copies of construction details indicating the method of construction of the jetty endorsed in ink by a professional engineer. The engineer must also confirm that the jetty will not impact on the structural integrity of the existing canal wall;

In addition to the above information, the attached checklist must be completed and included in any planning application, and included in a building application where only a building licence is required for a jetty.

Where an application is deemed to require consultation with adjoining landowners under the provisions of Local Planning Policy No 11 – Canal Waterways Structures, such consultation shall be undertaken by the City through its assessment process, and will incur an additional advertising fee of \$50.

Once the City has granted planning and building licence approval to the structure, a separate application is required to be made to the Department of Transport (Coastal Facilities), who will require the City of Mandurah's planning and building licence approval for the structure (letter and plans).

Administration Centre: 3 Peel Street, Mandurah WA 6210
Postal Address: PO Box 210, Mandurah WA 6210
Tel: 08 9550 3777 Fax: 08 9550 3888
Email: council@mandurah.wa.gov.au Website: www.mandurah.wa.gov.au



Checklist for Assessment Requirements of Jetties and Moorings Piles

(To be completed by the applicant and included in the information provided with a planning and building licence application)

Application and Plan Information

	YES	NO
Has the landowner signed the Planning Application Form? (NB: If the dwelling associated with the proposed jetty is part of a strata development, the strata company (body corporate) will be required to endorse the applications)	<input type="checkbox"/>	<input type="checkbox"/>
Does the proposed Jetty only require a building application?	<input type="checkbox"/>	<input type="checkbox"/>
Have the required plans been provided? (i.e. 3 copies for Planning Application & 2 for a Building application)	<input type="checkbox"/>	<input type="checkbox"/>
Have the Plans provided the following:		
- Appropriate scale (1:100 or 1:200 only)	<input type="checkbox"/>	<input type="checkbox"/>
- The proposed jetty, mooring or boat lifting structures width and length	<input type="checkbox"/>	<input type="checkbox"/>
- The dimensions of the subject lot, jetty envelope and mooring envelope	<input type="checkbox"/>	<input type="checkbox"/>
- The correct alignment of the canal wall in relation to the proposed structure	<input type="checkbox"/>	<input type="checkbox"/>
- Location of all mooring piles. (Existing and proposed)	<input type="checkbox"/>	<input type="checkbox"/>
Two copies of the construction details indicating the method of construction of the structure endorsed in ink by a structural engineer.	<input type="checkbox"/>	<input type="checkbox"/>
If the jetty is attached to the canal wall or if any part is closer than 50mm to the canal wall, a professional engineer must certify in writing that the jetty has been designed to ensure that it will not compromise the structural integrity of the canal wall as a result of either horizontal or vertical loads? (i.e. weight and loading of jetty or impact on jetties by vessels). The engineer must also certify that the canal wall has been inspected and suitable for the method of connection shown.	<input type="checkbox"/>	<input type="checkbox"/>

Details of Jetty

What is the length of the vessel proposed to be moored at the jetty? _____Metres

Details of Jetty Cont.

	YES	NO
Is the jetty a maximum length equal to 1.5 times the length of the boat proposed to be moored at the jetty?	<input type="checkbox"/>	<input type="checkbox"/>
Will the vessel be accommodated within the designated mooring envelope?	<input type="checkbox"/>	<input type="checkbox"/>
Is the proposed structure within the approved jetty envelope for the subject lot?	<input type="checkbox"/>	<input type="checkbox"/>
Is the jetty deck width less than 2 metres?	<input type="checkbox"/>	<input type="checkbox"/>
Is the primary walkway width greater than 900mm, but less than 2 metres? (i.e. a walkway where a vessel is intended to be moored to).	<input type="checkbox"/>	<input type="checkbox"/>
If a secondary walkway, is proposed, (i.e. A walkway where a vessel is not intended to be moored to), is the width greater than 600mm but less than 2 metres?	<input type="checkbox"/>	<input type="checkbox"/>
What type of jetty is proposed?		
Floating	<input type="checkbox"/>	<input type="checkbox"/>
Finger	<input type="checkbox"/>	<input type="checkbox"/>
"T" Shape	<input type="checkbox"/>	<input type="checkbox"/>
"L" Shape	<input type="checkbox"/>	<input type="checkbox"/>
A roofed structure, whether temporary or permanent, is not proposed to be erected on the jetty or over a mooring?	<input type="checkbox"/>	<input type="checkbox"/>
Is a boat lifting device proposed? (NB: Separate Planning Application Required)	<input type="checkbox"/>	<input type="checkbox"/>

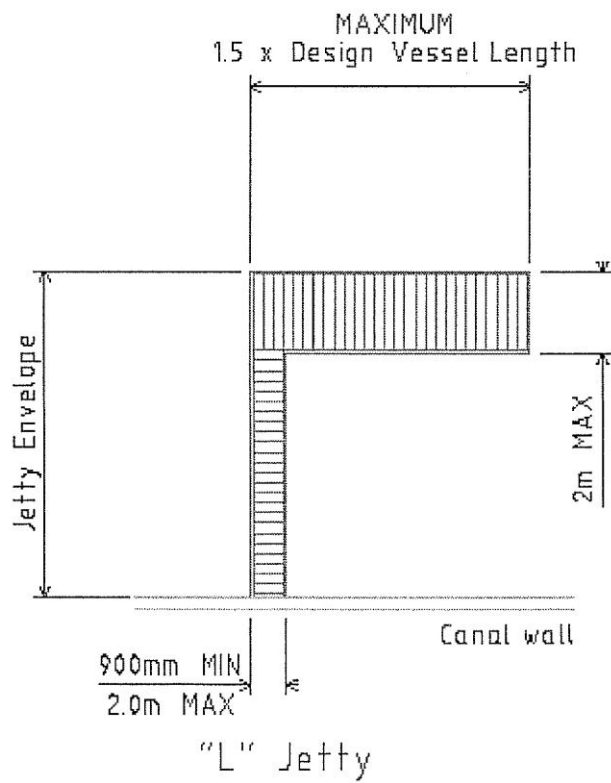
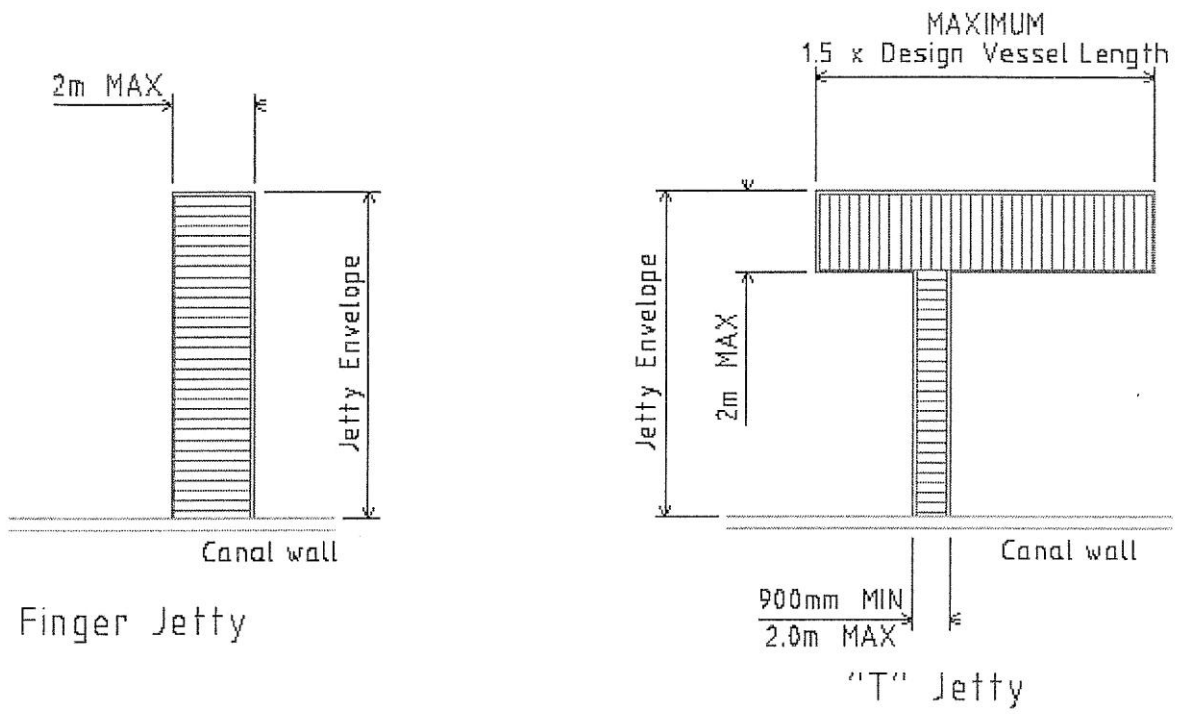

Jetty Deck Layouts